

**JH Solar**

# Hydrogen energy storage steam turbine



## Overview

---

es and an increased request for green energy. Due to the fluctuating nature of these energy sources, reliable storage is needed and additionally highly efficient power cycles able to convert energy from storage back to useful energy. Hydrogen is a promising energy carrier that can be produced when.

es and an increased request for green energy. Due to the fluctuating nature of these energy sources, reliable storage is needed and additionally highly efficient power cycles able to convert energy from storage back to useful energy. Hydrogen is a promising energy carrier that can be produced when.

Hydrogen-Fired Steam Generation is a patent-pending technology capable of driving megawatt-scale steam-turbine generator sets in commercial power plants, generating steam directly from the combustion of a fuel-mix composed of hydrogen and oxygen gases in stoichiometric proportion. The intense heat.

Steam Turbine for Electricity Generation with Hydrogen: A steam turbine generator is a device that converts thermal energy from steam into mechanical energy and then into electrical energy. This process involves the expansion of high-pressure steam through a turbine, which rotates a shaft connected.

Hydrogen Energy Storage and Power-to-Gas NREL is a national laboratory of the U.S. Department of Energy, Office of Energy Efficiency and Renewable Energy, operated by the Alliance for Sustainable Energy, LLC. Storage equates to. Capacity is valued at \$150/kW-year Source: Pfeifenberger, J.P.;

## Hydrogen energy storage steam turbine

---



### From green hydrogen to electricity: A review on recent advances

P2H2P systems have already been considered in several studies. Genovese et al. [4] presented a review study on potential hydrogen applications in Europe, including the ...

### Gas and Steam Turbines Adapt

Its Hydaptive green hydrogen packages augment renewables with on-demand power from gas turbines and lithium-ion battery storage, and green hydrogen production and ...



### Hydrogen gas turbine offers promise of clean ...

The technology development and demonstration of the hydrogen gas turbine is a part of KHI's long term commitment for establishing a hydrogen supply chain from production to transportation

### GTHandbook-final-edits-new dd

Serious hydrogen-fueled turbine development program primarily comes from the initiatives of the Japanese government in 1992, through its New Energy and Industrial Technology ...



## DOE ESHB Chapter 11 Hydrogen Energy Storage

As hydrogen has additional benefits outside of the electric grid, a hydrogen-based energy storage system could be the connection point to other energy sectors currently dominated by fossil ...

## Hydrogen-oxygen steam generator applications for increasing the

The comparative feasibility study of the energy storage technologies showed good applicability of hydrogen-oxygen steam generators (HOSG) based energy storage ...



## Steam Turbine for Electricity Generation with Hydrogen

By combining oxygenated fuels with renewable energy sources, energy storage, and advanced turbine technologies, steam turbines can play an essential role in the transition ...

## Iron piloted for seasonal hydrogen storage

The use of iron as a low cost approach for storing hydrogen is being piloted by researchers at the ETH Zurich in Switzerland. The approach relies on the reaction of hydrogen ...



## Turbines driven purely by hydrogen in the pipeline

In 2018, Tanimura's team, with the support of the Japan's New Energy and Industrial Technology Development Organization (NEDO), developed a gas turbine that runs on 30% hydrogen and 70%

## Powering the Hydrogen revolution -- ABB Group

Presently we are seeing growth of green hydrogen - produced using electricity generated from renewable sources such as solar or wind. Green hydrogen can be used to decarbonize manufacturing ...

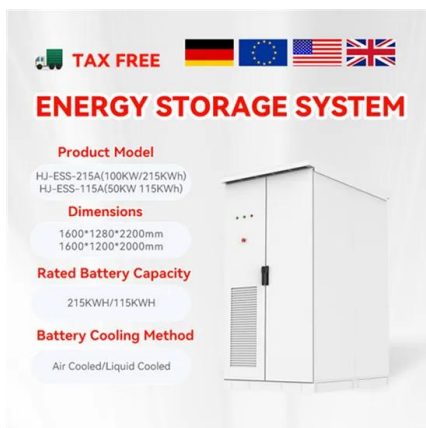

## Hydrogen-based combined heat and power systems: A review of

Abstract This article comprehensively reviews hydrogen-based Combined Heat and Power (CHP) systems as an ideal energy system for reducing environmental pollution and ...

## Gas turbine operating as part of a thermal power plant with hydrogen

One of the modern methods for implementing these challenges is the use of energy storage devices. A new solution to this problem can be the introduction of hydrogen ...



## Assessment of power-to-power renewable energy storage based ...

However, the aim of the paper is to highlight there is still a large margin to increase Power-to-Power round-trip efficiency, mainly from the hydrogen production and power ...

## Utilization of hydrogen in gas turbines: a comprehensive review

Hydrogen energy is one of the most attractive alternatives for the currently used fossil fuels with several superiorities, such as zero-emission and high energy content. ...



## A review of hydrogen utilization in power generation and ...

Especially this review will focus on the hydrogen application in power generation and transportation sectors using fuel cells, gas turbines, and internal combustion engines (ICEs).

## Gas turbine innovation, with or without hydrogen

Gas turbines are now expected to burn more variations of fuel and be more flexible in their application, all while competing with wind, solar, and battery storage systems. ...



## HYFLEXPOWER: The world's first integrated power-to-X-to-power hydrogen

The consortium selected following the call for proposals is made up exclusively of European companies and bodies. Each stakeholder's role is defined as follows: Engie ...

## Analysis of efficient hydrogen fuelled steam Analysis of ...

Analysis of efficient hydrogen fuelled steam cycle for power production SOFIA WIELL Department of Space, Earth and Environment Division of Energy Technology



## Combined cycle gas turbine for combined heat and ...

Combined cycle gas turbine for combined heat and power production with energy storage by steam methane reforming September 2021 Journal of Energy Systems 5 (3) DOI: 10.30521/jes.936064 License

## Hydrogen utilization by steam turbine cycles

Experimental H<sub>2</sub>/O<sub>2</sub>-steam generators, with capacity of up to 25 MW(t), were created and the peculiarities of their use in steam-turbine hydrogen power units were experimentally studied.



## Hydrogen-Capable Gas Turbines for Deep Decarbonization

THE VALUE Robust low-NO<sub>x</sub> gas turbines capable of producing power from low-carbon fuels such as hydrogen could enable natural gas assets and infrastructure to be leveraged as a ...



### DETAILS AND PACKAGING



## Hydrogen-Fired Steam Generation as an Alternative to Coal

Hydrogen-fired steam generation is the only technology available worldwide, capable of generating gigawatt-scale electric power from energy stored in the form of hydrogen ...



## Hydrogen production and solar energy storage with thermo

Hydrogen is widely regarded as a sustainable energy carrier with tremendous potential for low-carbon energy transition. Solar photovoltaic-driven water electrolysis (PV-E) is ...

## Gas and Steam Turbines Adapt

Its Hydaptive green hydrogen packages augment renewables with on-demand power from gas turbines and lithium-ion battery storage, and green hydrogen production and storage.



## **Integrating Hydrogen as an Energy Storage for Renewable Energy ...**

Increasing global focus on renewable energy sources highlights the need for effective energy storage solutions especially considering the intermittent nature of these renewables. This ...

## **Storage and regeneration of renewable energy via hydrogen**

Storage and regeneration of renewable energy via hydrogen - A novel power system integrating electrified methane reforming and gas-steam combined cycle



## **Hydrogen power storage, delivery possible at room temperature ...**

Hydrogen power storage, delivery possible at room temperature without freezers As much as 40 percent of energy is lost when hydrogen is pressurized or liquified for storage ...

## CPS Energy\_Power Gen Technologies\_Brochure\_Final Rev.

The generating facilities covered in this document include combustion turbines, boilers, combined cycle, coal, nuclear, reciprocating internal combustion engines, hydroelectric, wind, solar, ...



## Hydrogen Energy Storage and Power-to-Gas

NREL is a national laboratory of the U.S. Department of Energy, Office of Energy Efficiency and Renewable Energy, operated by the Alliance for Sustainable Energy, LLC.

## HYDROGEN-BASED UTILITY ENERGY STORAGE SYSTEM

Currently, SRT is developing an electrical energy storage and hydrogen production concept through cost-shared programs with the DOE. This concept requires the integration of two sub ...

ESS



## Sustainable energy storage solutions for coal-fired power plants: ...

Sustainable energy storage solutions for coal-fired power plants: A comparative study on the integration of liquid air energy storage and hydrogen energy storage systems

## Zero Emission Hydrogen Turbine Center (ZEHTC)

Within our research project ZEHTC we develop a Zero Emission Hydrogen Turbine Center in Finspång, Sweden, connecting gas turbines with hydrogen, renewable energy and energy storage.

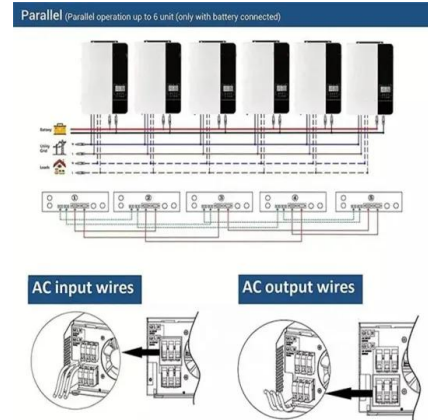
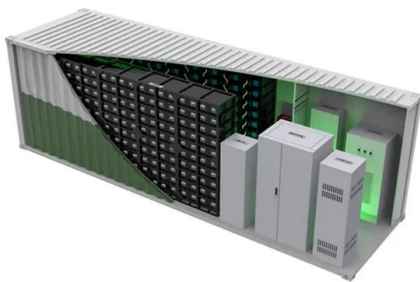

## Hydrogen for Power Generation Whitepaper

This paper will provide an update on how gas turbines can support a low or reduced carbon electrical grid by operating on a wide variety of lower carbon fuels, including current hydrogen ...

## Contact Us

For catalog requests, pricing, or partnerships, please visit:  
<https://apartamenty-teneryfa.com.pl>